

Advanced Motorized Positioning Capability

Brightline has introduced second-generation motor capability to our T-Series fixtures. Adding a motor module provides the T-Series fixtures with self-contained, independently addressable motion capability, which enables rotating the luminaire lamp carriage from its horizontal axis to angular positions through +/-50 degrees from the down-light position with 1-degree incremental resolution. T-Series fixtures so equipped are stand-alone "nodes", which may also be interconnected via 6-conductor data cable with RJ-25 plugs to comprise a "node control network". The "node control network" facilitates simultaneously orienting more than 100 luminaires within a span of a few seconds. Luminaire node control networks are typically supervised by AV / building automation controllers, via serial protocol RS-232 / RS-422.

Onboard memory provides for up to 60 unique scenes on a node control network of up to 1000 feet total length in standard configuration. Special configurations for greater network lengths are possible upon request.

Motor modules accept universal single-phase AC power (120-230 VAC 50/60Hz) and draw approximately 12 Watts.

For information concerning the lamps, drivers, fluorescent ballasts and dimming systems please refer to the T-Series fixture data sheets.

Construction

Fixture housing is made of formed, cold-rolled sheet steel. Dome-shaped interior fixture housing. Perforated filler panels are optional.

Fixture Body Finish

Low-gloss, off-white finish (Tiger Drylac #44911704) is standard, with custom colors available.

Fixture Carriage and Reflector

Two sizes of lamp carriages are available, housing one or two 55-W lamps. Reflectors are of formed-aluminum specular-sheet-metal construction, featuring 95% reflectance.

Shipping Information
Length: 27 in (686 mm)
Width: 25.5 in (648 mm)
Height: 8 in (203 mm)
Weight: 28 lb (12.8 kg)



* Fixture shown with Two-Lamp Rotate carriage.



Ballast

Ballasts are available in switched or in a variety of dimmable configurations. All ballasts are high-frequency electronic, with a Power Factor > .97, THD < 10%, and a Class A sound rating. Ballasts are installed in the fixture housing. Power and control inputs are from the side.

Lamps

All Brightline fixtures use 55-W compact fluorescent lamps, available in a variety of color temperatures and CRI ratings (see the Fixture Accessories and Lamps datasheet for details). Studioline and Cinema Series lamps are optimized specifically for video camera applications.

Articulation

Motorized: Fixtures with motorized articulation are available in a configuration featuring a two-lamp carriage. Offers angular movement (+/- 50 degrees) on a single axis.

Accessories

A variety of control screens are available to shape the light-beam pattern (see the Fixture Accessory and Lamps datasheet for details). White-finish screens are standard, with Black-finish as an option. Prismatic lenses are available for one- and two-lamp carriages.

Fixture Dimensions

Inch Panel: 23.750 x 23.750 x 7.04 in
 (603.25 x 603.25 x 178.816 mm)

Metric Panel: 595 x 595 x 178.816 mm
 (23.43 x 23.43 x 7.04 in)

Fixture Weight: 25 lb (12 kg)

Electrical Certifications

UL, cUL, CE, and C-Tick

US Patent No. 6,517,216. Other US and foreign patents pending.

Sample Motor System Riser Diagram

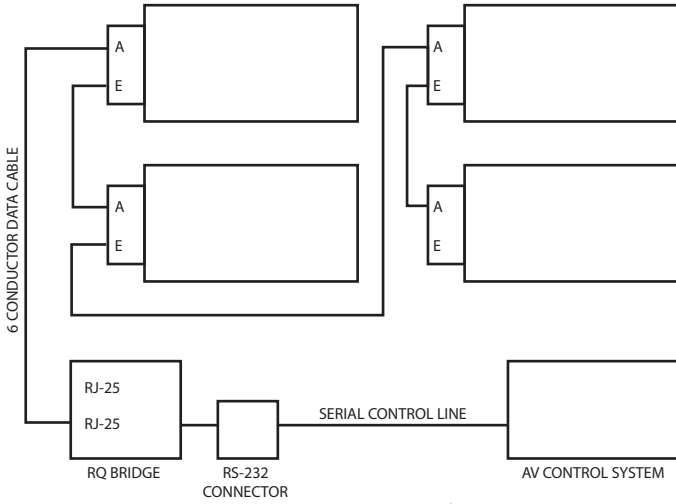

Note: Dimensions are in inches

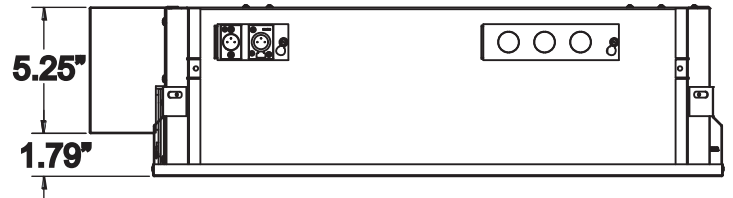
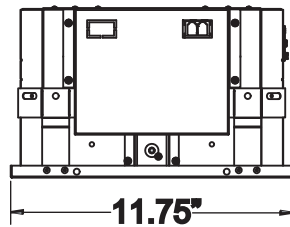
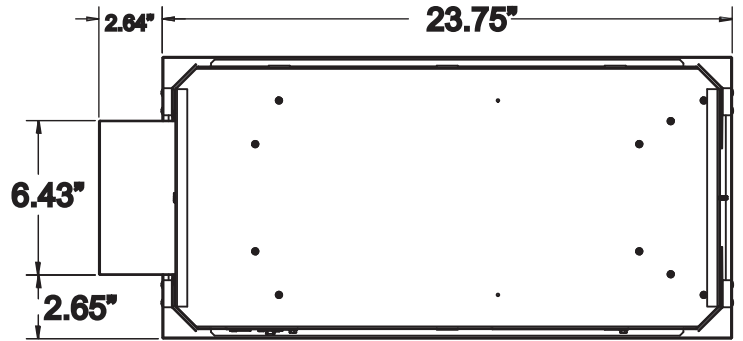
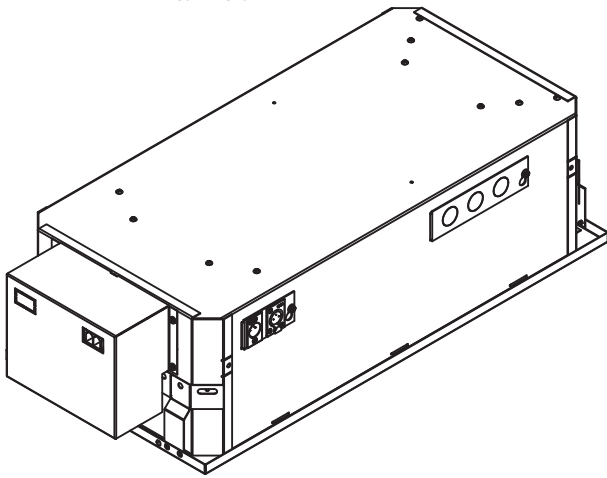

T			
T-Series	Lamp Carriage	Ballast Type	Voltage
	01= One 1-Lamp Carriage	E = Ecosystem	1 = 120v
	11= Two 1-Lamp Carriages	N = Non-Dim	2 = 230v
	02= One 2-Lamp Carriage	X = DALI	
		P = Phase	

M
Articulation
M = Motorized

S		
Panel Size	Panel Style	Mounting Style
I = Inch	S = Solid	MM = Mini Mount
M = Metric	P = Perforated	CM = Center Mount
		OM = Offset Mount
		45 = 45-Degree Mount

* Specifications subject to change