



1.2 N/1.2 D

Operating Instructions

Safety

- **Warning:** Do not dim a non-dim fixture.
- Do not remove the cover on the back of the unit until the appropriate service manual has been read and the unit has been completely de-energized.
- All fixtures are fuse protected.
- To prevent fire or shock hazard, do not expose the unit to water or moisture.
- Do not operate fixture without lamps installed. Operating the fixture without the lamp installed may result in damage to the ballast.
- Never carry energized fixtures with your hands close to the sockets or work with your hands near an exposed socket that is energized.
- Never remove or insert lamps into the fixture while it is energized.
- Service on the unit should only be performed by a qualified technician.
- In case of lamp failure:
 1. Turn fixture "OFF".
 2. Wait 30 seconds for ballast to reset.
 3. Install new lamp.
 4. Turn fixture "ON".

Owner's Record

- The serial number of this product can be found on the side of the main housing. You should note the model number and the serial number in the space provided and retain this book for future reference as a permanent record of your purchase.

Model No. _____

Serial No. _____

Date of Purchase _____

Product Description

- The brightline 1.2N/1.2D is a 2-lamp, 55-watt, energy-efficient light fixture. This fixture combines high-frequency electronics with a state-of-the-art optical system to produce a soft, full-spectrum, flicker-free light source.

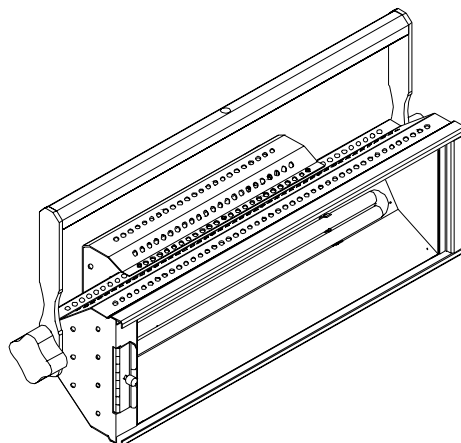

Installing the Yoke

1. Assemble palm handle, yoke and washers as shown (Fig. 1).

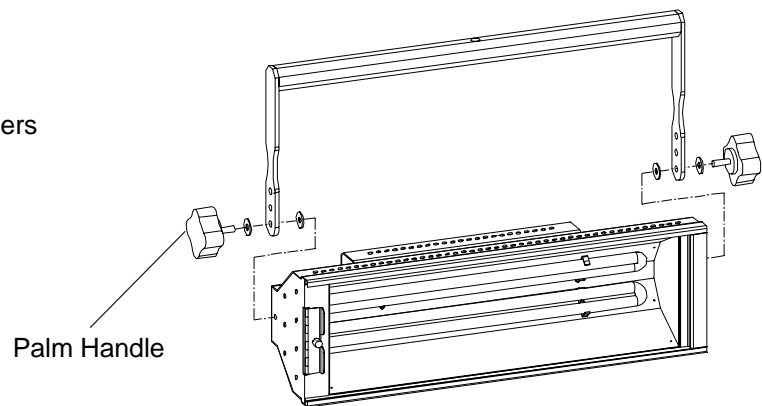

Figure 1

2. Screw palm handle into place (Fig. 2).

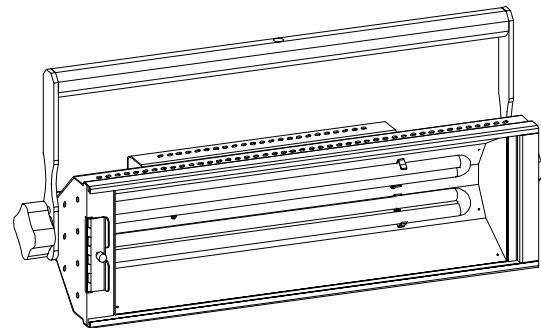

Figure 2

3. Repeat steps #1 and #2 for remaining palm handle.

Adjusting the Yoke

1. While firmly grasping fixture, loosen palm handles (Fig.3).
2. Adjust tilt of fixture, as desired.
3. Retighten palm handles.

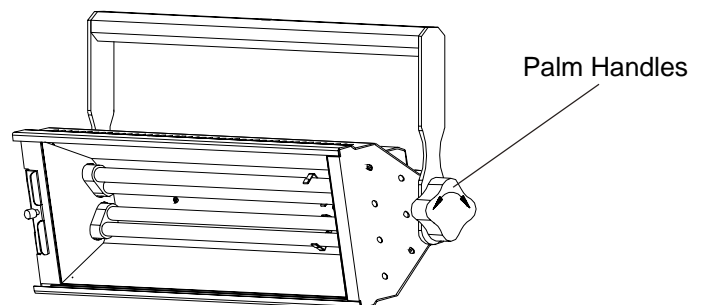

Figure 3

Installing Lamps

1. Place lamp into clip as shown in (Fig. 4).

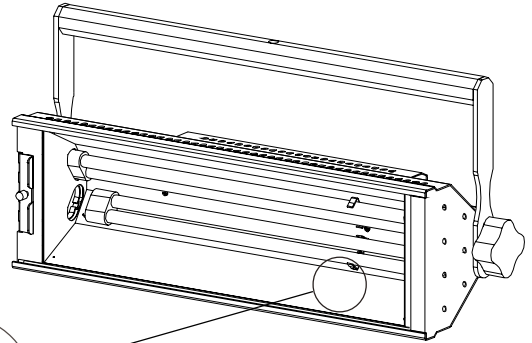
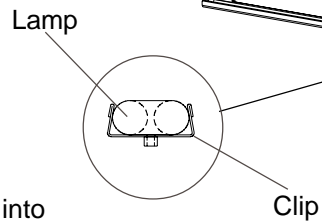

Figure 4

2. Gently slide lamp into socket (Fig. 5).

Note: The socket's locking tabs will snap into indents on the base of the lamp.



3. Repeat steps #1 and #2 for remaining lamps.

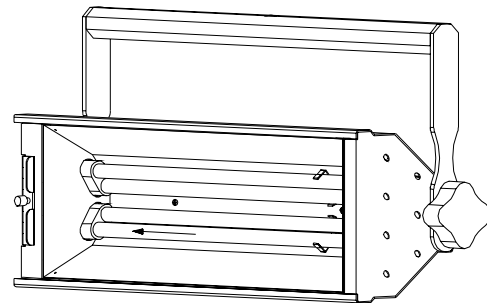

Figure 5

Installing Adapters (C-clamp/Spud)

1. Thread mounting screw through yoke and into adapter (Fig. 6).

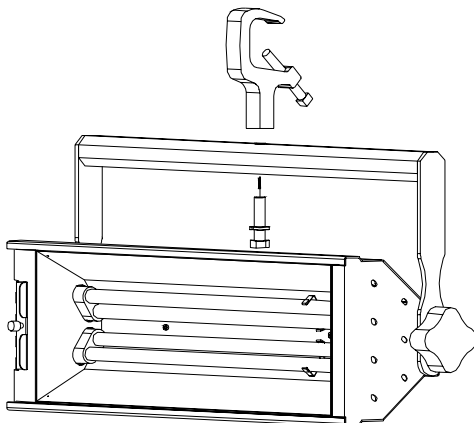

Figure 6

2. Tightly fasten mounting screw in place (Fig. 7).

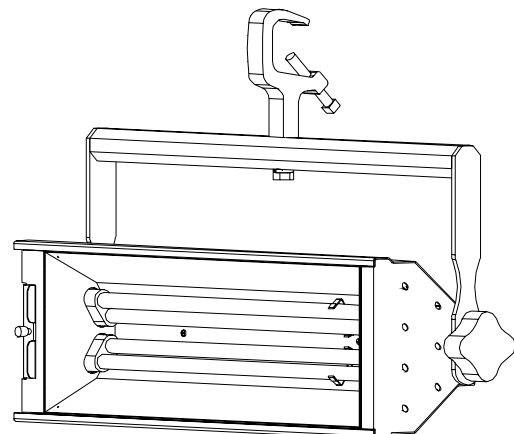

Figure 7

Installing Accessories

1. Swing latch open (Fig.8).

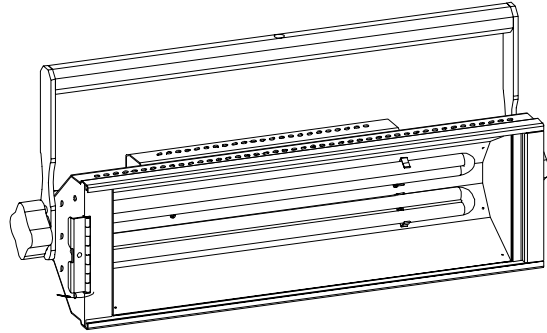

Figure 8

2. Insert accessory into the track and slide it forward until it stops (Fig. 9).

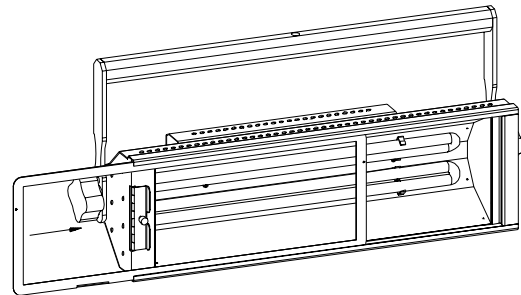

Figure 9

3. Swing latch closed and fasten in place (Fig. 10).

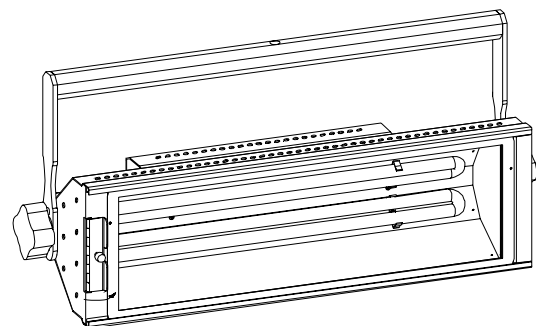

Figure 10

Replacing Fuse

1. Pull fuseholder out of power inlet module.
2. Remove fuse holder and check for wear (Fig. 11). If fuse is blown, replace with a new fuse or the on-board spare (Fig. 12).
3. Return fuseholder to a closed position.

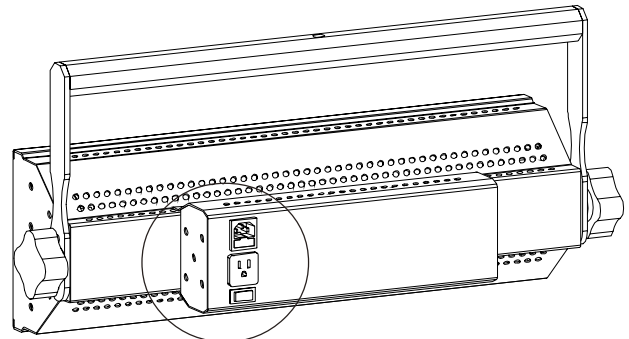

Figure 11

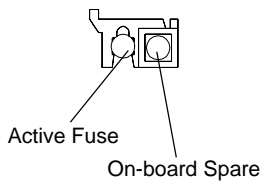
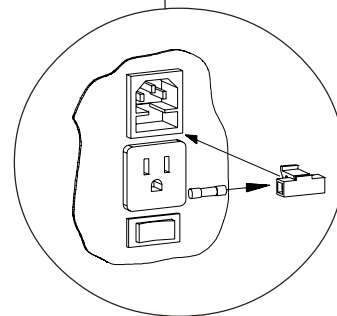

Figure 12

Note: Replace fuse only with 8-amp, time-delay, 250-volt, 5 x 20-mm fuses.



Installing Power Cord

1. The IEC320 connector mates with the power inlet module (Fig. 13).

Note: The ON/OFF switch should always be in "OFF" position when either installing or removing the power cord.

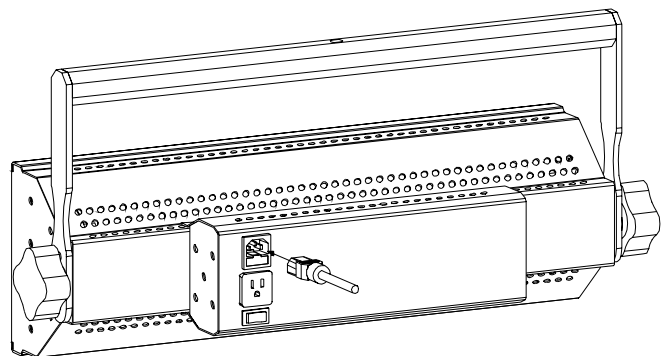

Figure 13

Trouble Shooting Guide

Problem	Possible Cause	Solution
Lights flicker or drop out at low end.	Defective or damaged lamps.	Replace with new lamps or exchange lamps from a known good fixture.
Lights are flashing or strobing.	Wrong voltage for ballast installed.	Verify that the ballast's voltage is correct.
Lamps are not at the same light level.	Mixture of lamp ages or color temperature.	Check that all the lamps are the same exact type (both age and color).
Ballast buzzes or hums.	Defective ballast.	Identify location of buzz and replace ballast if necessary.
Light fixture does not turn "on."	Defective or missing fuse.	Install fuse into power entry module.

Maintenance

- Lamps should be changed every 10,000 hours.
- For maximum performance, season lamps 100 hours before use.
- Clean reflector with a dry, non-abrasive cloth.
- Replace fuse with only 8-amp, time-delay, 250-volt, 5 x 20-mm fuses.

Specifications

Housing: 14-gauge (.060) formed, aluminum sheet metal construction. See finish note.

Reflector: 24-gauge (.020) formed aluminum sheet metal construction. Polished spectral finish. 95% specular reflectance.

Ballast:

Non Dim: (1) 2-lamp, 55-watt, high-frequency electronic ballast. 120VAC/60Hz or 230VAC/60Hz, Power factor = >.97 Class, "A" sound rating and THD: <20%.

Dim: (1) 2-lamp 55 watt high-frequency, phase control electronic ballast. 100-240 VAC 50/60 Hz, Power factor = >.97, Class "A" sound rating and THD: <20%.

Lamp: (2) 55W/21T5/T/2G11RS 3000°K and 5000°K available. 10,000-hour-rated lamp life.

Lamp Socket: 2G11 4-pin. Molded white high-strength thermoplastic. Push wire connections for 18-gauge leads.

Mounting: 10-gauge (.125) extruded aluminum yoke welded construction (standard). 2" O.D. pipe clamp or TVMP adapter provided.

Power Entry Module: 10-amp fuse (with on-board spare) and IEC connector incorporated within housing.

Finish: Low glare, polyester powder coat.

Switch: Rocker ON/OFF power switch.

Optional Accessories: Fixture screens, intensifier, intensifier screens, snoot and gel frame.

Power Cord: 12' length, 3/18 gauge SOW cable 10 amp/250 V. IEC320 connector to grounded Edison (3) prong plug - NEMA 5-15P standard. (Optional connectors available upon request.) Black finish.

Exploded Assembly

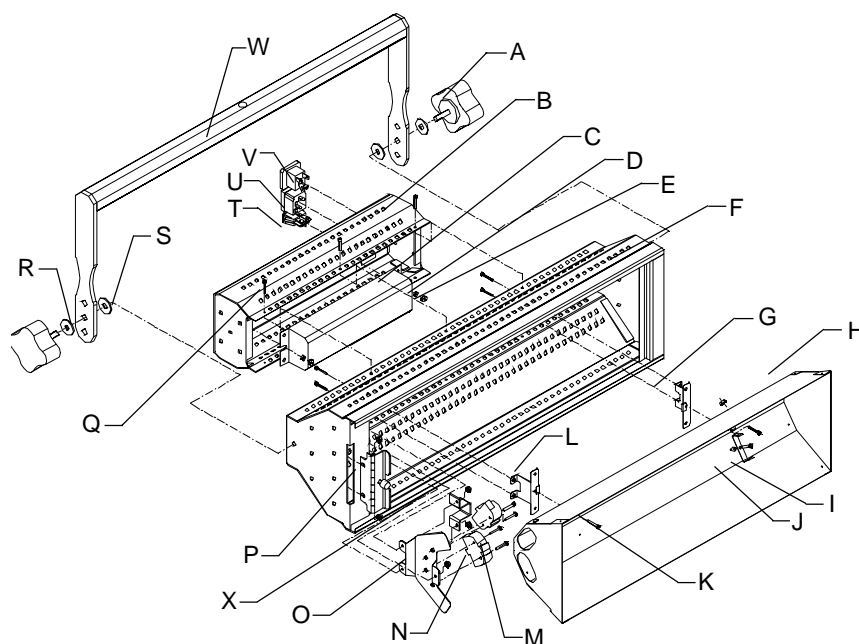

- A - Palm Handle
- B - Ballast Housing
- C - Ballast
- D - #6 Washer
- E - #6-32 Nut
- F - Main Housing
- G - Reflector Bracket
- H - Reflector
- I - Lamp Clip
- J - Nylon Spacer
- K - #6-32 x .25 lg. Screw
- L - #6-32 Tinnerman Nut
- M - #4-40 X .25 lg. Screw
- N - Socket
- O - Socket Bracket
- P - Accessory Latch
- Q - #6-32 x .25 lg. Black Oxide Screw
- R - Nylon Washer
- S - Cork Washer
- T - Rocker Switch
- U - Power Inlet Module
- V - Receptacle
- W - Yoke
- X - Wire Guard Bracket

Wiring Diagram - Dim

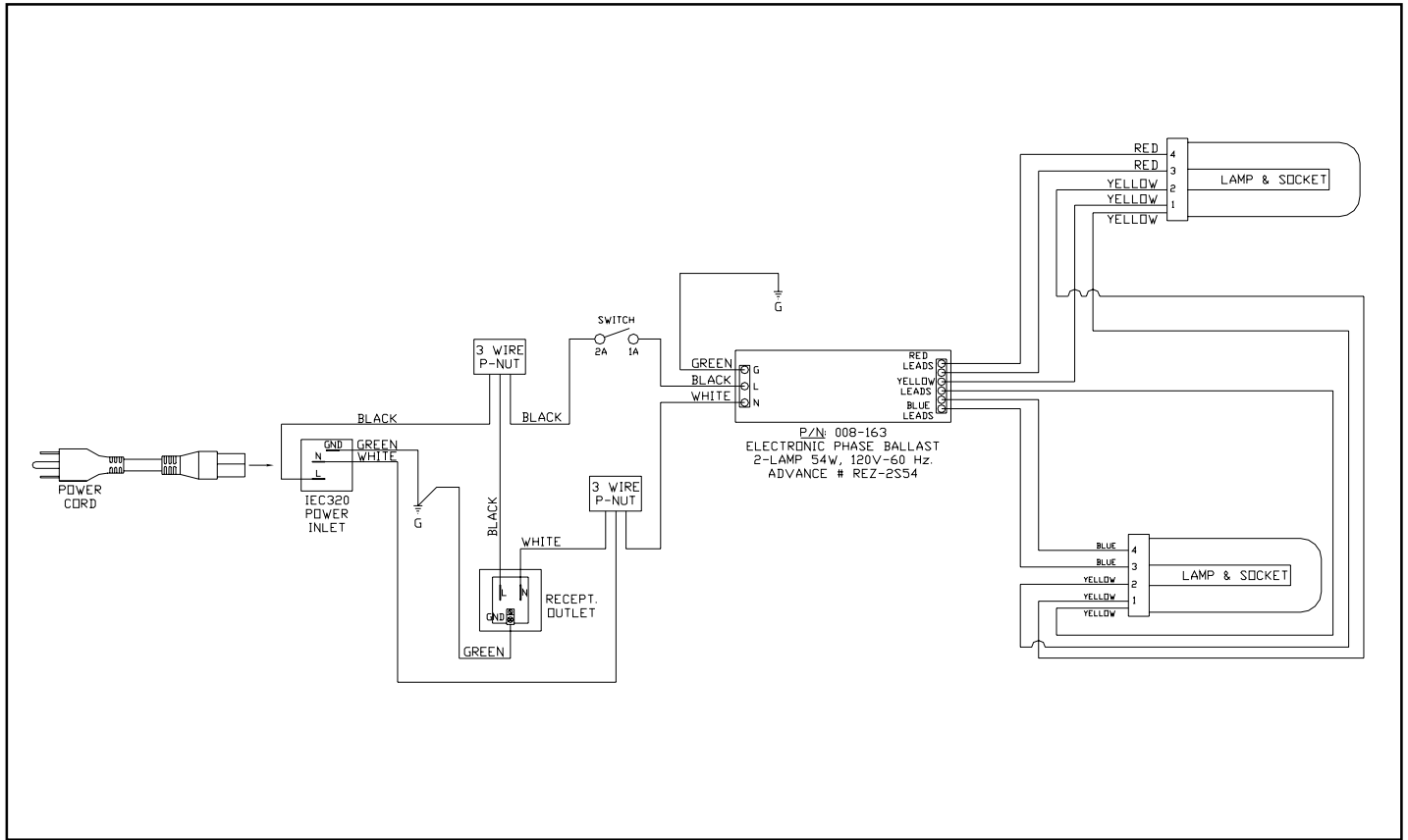

Wiring Diagram - NonDim

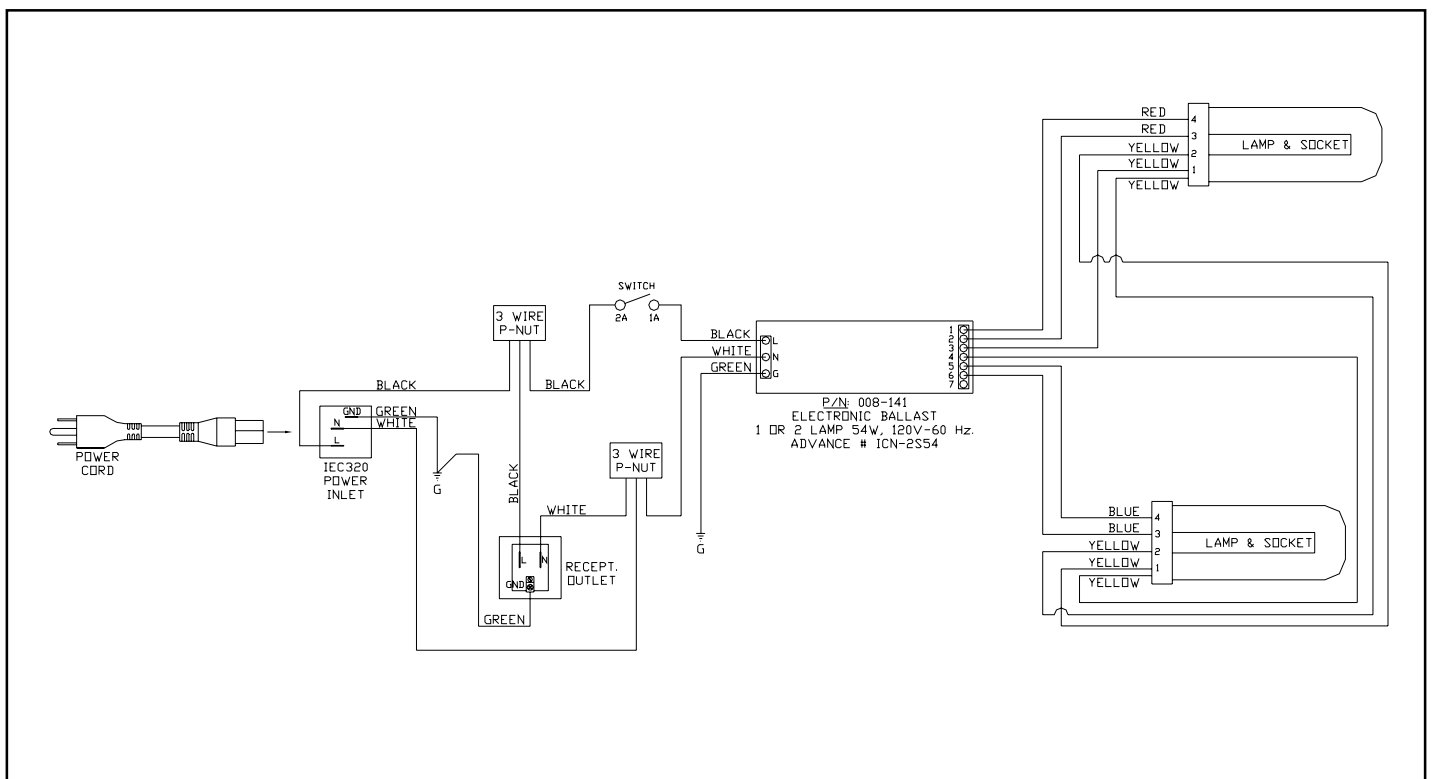



brightline®

WARRANTY

brightline guarantees all its products to be free from defects in materials and workmanship for a period of one (1) year from the date of shipment.

PROCEDURES

If any product is found to be unsatisfactory under this warranty, the buyer must notify **brightline** immediately. Once a course of action has been determined, if it is necessary to return the product to **brightline** a Return Authorization (RA) will be issued. Ship the product directly to **brightline**, 580 Mayer Street, Building #7, Bridgeville, PA 15017. The RA number should be marked on the shipping carton. The unit will be replaced or put into proper operating condition, free of all charges. The correction of any defects through repair or replacement by **brightline** shall constitute fulfillment of all obligations and liability of **brightline** to the buyer under this warranty and the contract of sale.

DISCLAIMERS

brightline is not responsible for damage to its products caused by improper installation, maintenance, or use; by improper electrical hookups; or by unauthorized repairs.

Failure to notify **brightline** of unsatisfactory operation or any improper or unauthorized installation, maintenance, use, repairs, or adjustments shall terminate the warranty and **brightline** shall have no further responsibility under the warranty. **brightline** shall not be liable for special or consequential damages in any claim, action, suit, or proceeding arising under this warranty or contract of sale, nor shall **brightline** be liable for claims for labor, loss of profits or goodwill, repairs, or other expenses incidental to replacement. **brightline** makes no other warranty of any kind whatsoever, expressed or implied, and all implied warranties of merchantability and fitness for a particular purpose that exceed the obligation specifically described in this warranty are hereby disclaimed by **brightline** and excluded from this agreement. All shipments, unless otherwise noted, are F.O.B. factory. The customer is advised to inspect for shipping damage, apparent and/or hidden. If detected, notify the transportation company and file your claim.

580 Mayer Street, Building #7, Bridgeville, PA 15017 • phone 412.206.0106 • fax 412.206.0114

www.brightlines.com

Notes